



شرکت زاگروس کاروسل

ZAGROS Karussell Co.

تهران، شهر قدس، بلوار کلهر، بلوار شهیدا، خیابان ساحل، خیابان سرو، پلاک ۱۵ - کد پستی: ۳۷۵۱۱۳۳۵۳
تلفن: ۰۹۱۲ ۲۱۸۱ ۷۲۹ - ۰۹۰۳ ۵۱۳۹ ۲۴۰ - ۰۹۰۳ ۲۷۱۰ ۵۵۰

No. 15, Sarv-E-Sharghi St., Sahel St., Shohada Blvd., Kalhor Blvd,
Shahr-E-Qods, **Tehran, IRAN Postal Code: 375113353**

Tel: +98912 2181 729 - +98903 5139 240 - +98903 2710 550

zagroskarussell.irex2world.com

zagroscarusel@gmail.com



+989121692052

zagroskarusel@gmail.com

شهر قدس - بلوار کهر - بلوار شهیدا -
خیابان ساحل - خیابان سرو - پلاک ۱۵

شرکت زاگرس کاروسل
سازنده کاروسل‌های CNC با ابزار زنده

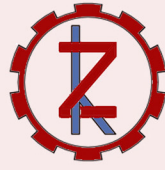

ZAGROS KARUSSELL Co
Vertical Lathe



Vertical Lathe with Live Tool
Model: K-1300 CNC



+989121692052

zagroskarusel@gmail.com

شهر قدس - بلوار کهر - بلوار شهیدا -
خیابان ساحل - خیابان سرو - پلاک ۱۵

شرکت زاگرس کاروسل
سازنده کاروسل‌های CNC با ابزار زنده



ZAGROS KARUSSELL Co
Vertical Lathe



*Vertical Lathe Power Chuck
Model: K-1000 CNC*

شرکت زاگرس کاروسل
سازنده کاروسل‌های CNC با ابزار زنده

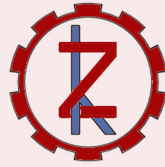

ZAGROS KARUSSELL Co
Vertical Lathe



*Vertical Lathe with movable Cross
Model: K-2000 CNC*

+989121692052

zagrosrosel@gmail.com

شهر قدس - بلوار کلهر - بلوار شهیدا -
خیابان ساحل - خیابان سرو - پلاک ۱۵



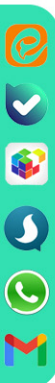

+989121692052

zagroscaroel@gmail.com

شهر قدس - بلوار کلهر - بلوار شهدا -
خیابان ساحل - خیابان سرو - بلاک ۱۵

Main Spindle /Table is on a Cross Roller Bearing (CRB) with 800mm Diameter for K-1000CNC

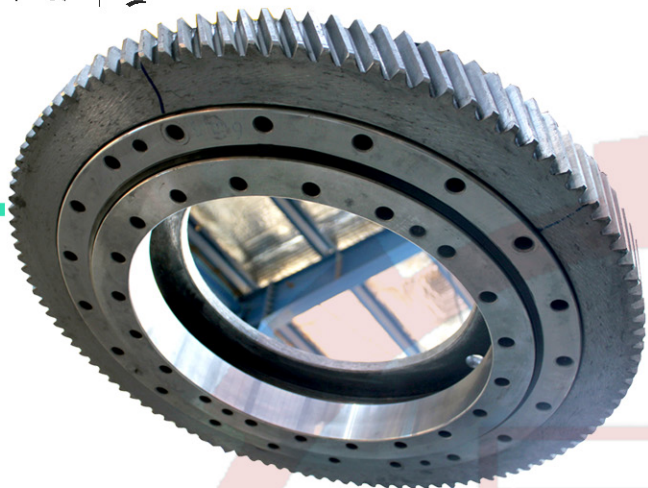

Cross Roller Bearing

CRB will Made a strong and permanent accurate machine also very fine surface for turning



Main Gear

CRB's accuracy is 0.005mm (radial & axial)

Lubrication of main gearbox, CRB, main gear and pinion bearings are automatically and continuous

Main Gear & Pinion



Surface quality is 0.8 μ m

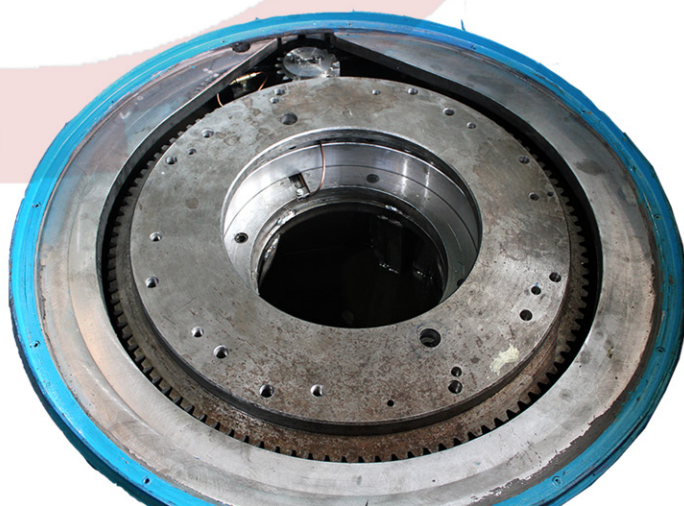

Run out max. is 0.01mm

Power Chuck

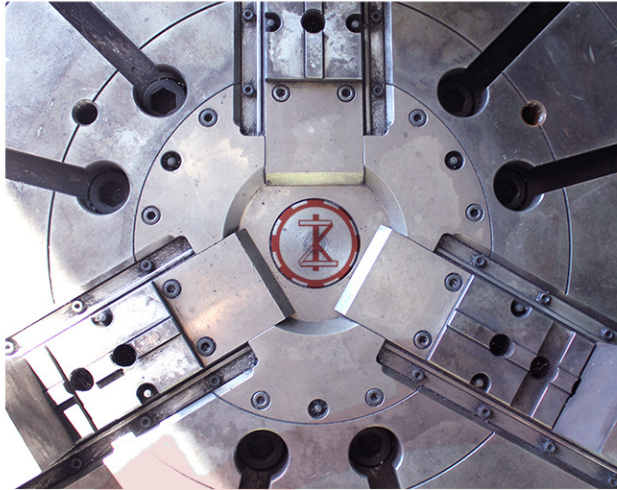

L.M Guide Roller is the maintenance free Guide (PEK) so there is no Backlash with C3 class Ballscrew (PEK)
Linear Encoder is 5mic.

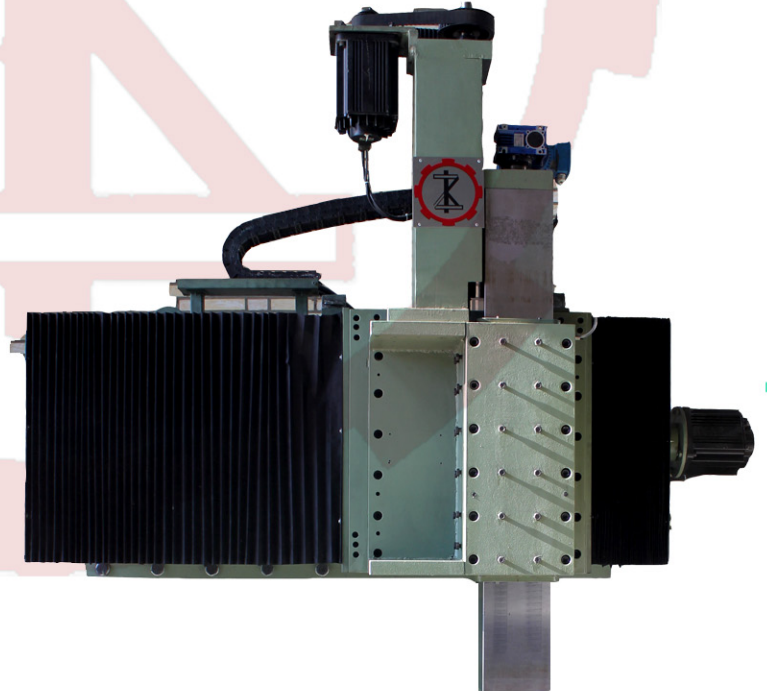
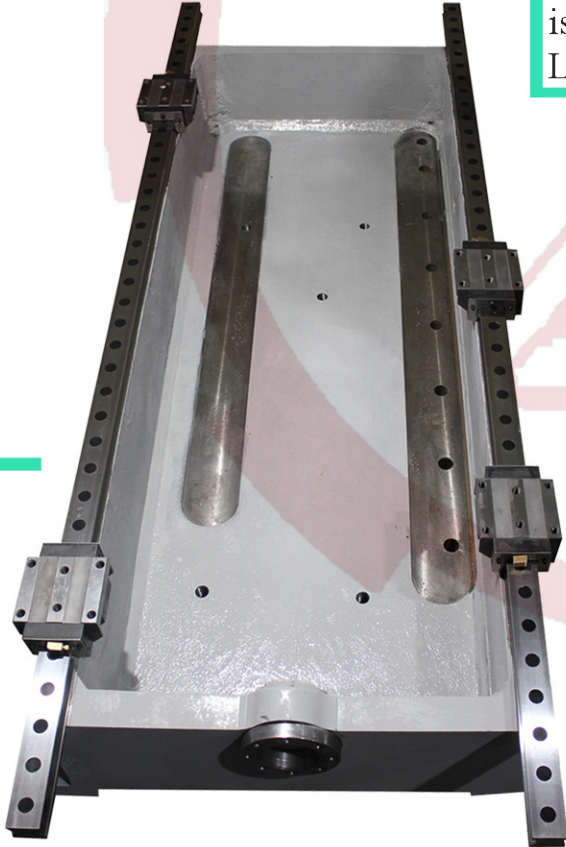

L.M. Guide for X-Axis

X-axis is L .M. Guide Roller type 45mm (in K- 1000CNC)

+989121692052

zagrosrosel@gmail.com

شهر قدس - بلوار کهر - بلوار شهیدا -
خیابان ساحل - خیابان سرو - پلاک ۱۵

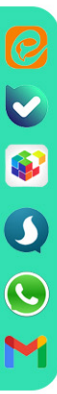

No.15 – Sarv-e-Sharqi St. – Sahel St.– Shohada Blvd. – Kalhor Blvd. – Shahr-e-Qods – Tehran – Iran
 Postal Code: 3751113353
 +982146010314 – 09121692052 – 09032710550
 zagroscaresel@gmail.com

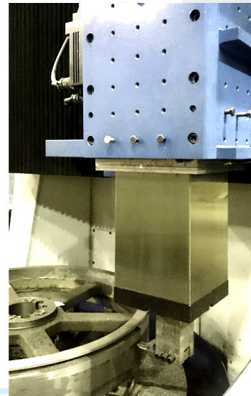
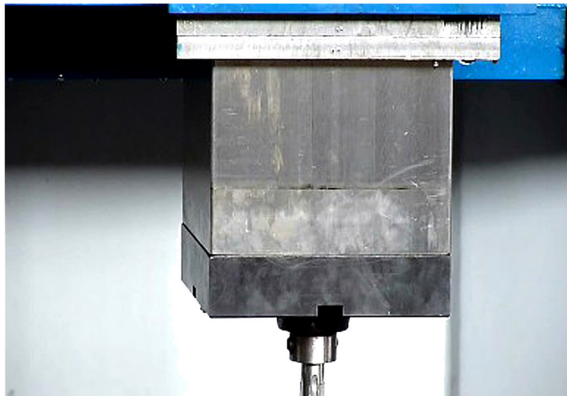
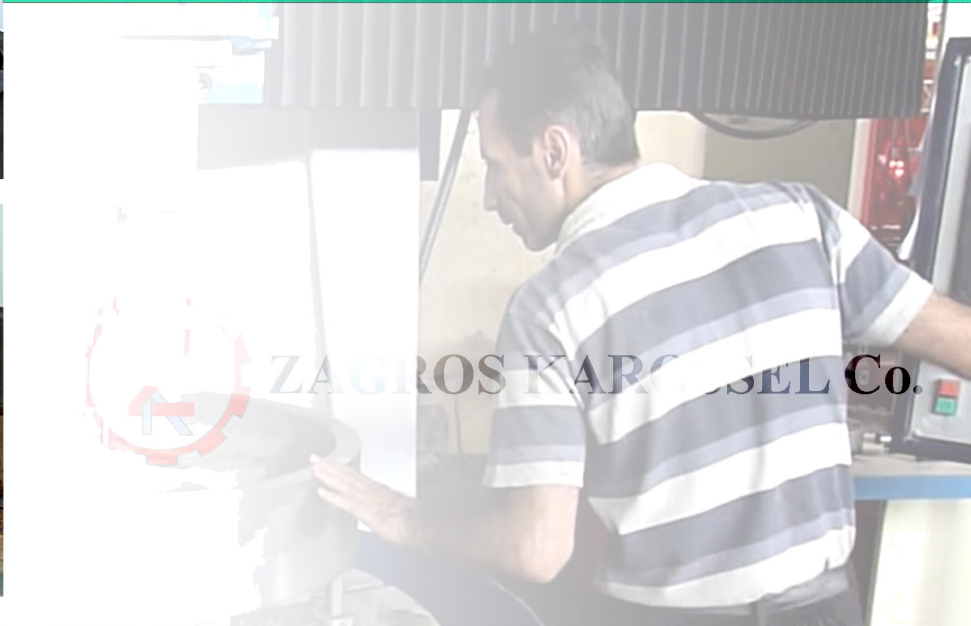
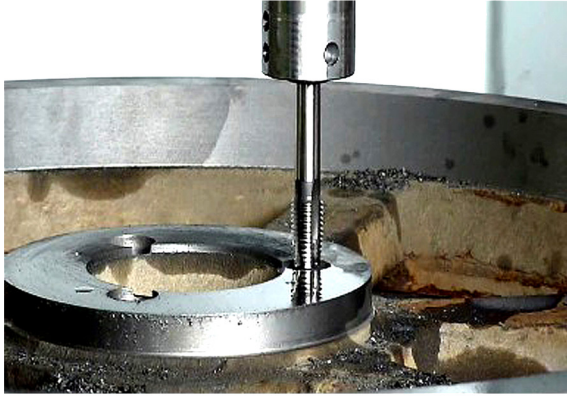
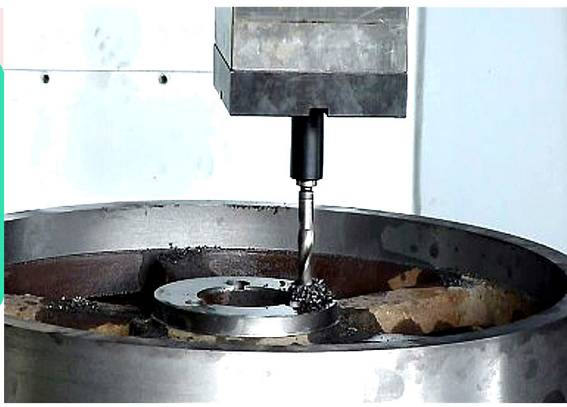

Table

Working area and tool Interference

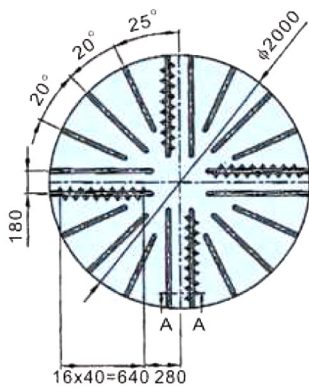

K-2000 Series

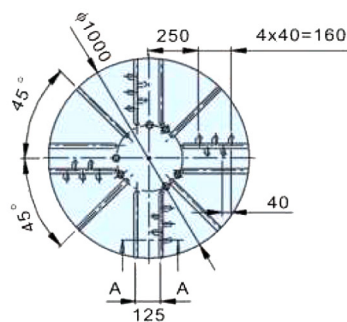

K-1000 Series

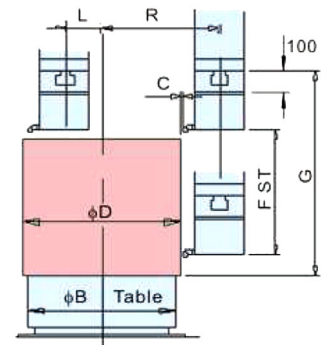
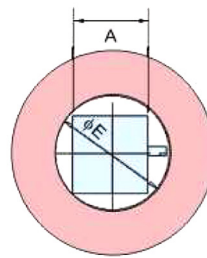

MODEL	A	øB	C	øD	øE	F	G	R	L
K-1000 CNC	200	1000	100	1250	300	700	900	700	80
K-1300 CNC	200	1300	100	1700	300	800	930	1000	80
K-1600 CNC	220	1600	100	1800	330	900	1100	1100	80
K-2000 CNC	250	2000	100	2300	360	900	650- 1200	1300	80

ZKCo Products

CNC Carousel by 2000, 1600, 1300, 1000mm diameter equipped with Live Tool
Tube Sheet Drilling Machine
Automatic Wagon Wheel Welding Machine
Full Bogie and Wagon Repair Line
CNC Floor Type Milling
Construction of automotive production line equipment for IKCO, Saipa, IKDCCO & Bahman Group
Etc.



Zagros Karussell Company, relying on modern technical knowledge and 40 years of experience in the field of machine tool industry, has been able to produce knowledge-based, effective and efficient products. This company is trying to help development of knowledge-based industry in various fields by investing in knowledge-based and innovative products.



ZAGROS KARUSSELL

خیابان ساحل - خیابان سرو - پلاک ۱۵
شهر قدس - بلوار کهر - بلوار شهیدا
zagroscarousel@gmail.com
+989121692052

